



TR Comfortline Bathtub

Hygiene Equipment
Designed for People

TR Comfortline - Colored options

The TR Comfortline is a free standing, height adjustable bathtub designed for a satisfying and relaxed bathing experience. With a host of sensory options available, such as LED lighting system, Music sound wave system with 4 speakers AUX and bluetooth and a 12 jet air-spa system. You pick the color, we build the bath. For additional information regarding customized colors please contact your TR representative.

CE



Registered at Medical Products
Agency, Sweden,
as a MD Class 1 product,
MDD 93/42EEC.

TR reserves the right to make
design changes and/or
improvements without notice.



TR EQUIPMENT



TR Comfortline Bathtub

Hygiene Equipment
Designed for People

Features

- Innovative and attractive design
- Easy to operate and learn - Quick introduction
- Easy access to the bathtub from three sides
- Compact design for easy placement
- Ergonomic tub shape
- Easy to clean and maintain
- Suitable for mobile transfers (TR 9650 with Stretcher/Chair is recommended.)
- Detached, no wall or floor fixing
- Reverse install configurations possible with extended hose kits

Standard Equipment

- Hand shower with long hose
- Overflow control and pop-up drainage incl drainage hose
- High quality bathtub with side covers of reinforced fibre glass
- White as standard color
- Two chrome grab handles
- Foot support, adjustable in three positions and removable
- Reinforced hoses for water installation
- Two wide stainless steel legs with adjustable feet

Options/Accessories available for Comfortline

- Cleaning/disinfection system
- Autofill with 2 different pre-set levels
- Bathtub and bathtub side covers in optional RAL - Color (Specify RAL code on order)
- Fixed height bath (650 mm) - ECOLINE
- FMM Antibactus mixer (Legionella)
- Mixer Grohe 2000, with Grohe CoolTouch system

Wellness Options

- Air bubbles from twelve integrated jets stimulate blood circulation and provide a calming environment for relaxation.
- LED Color Light System with light that changes the water into different colors.
- Music sound wave system with four speakers AUX and bluetooth.

Application Examples

Integrated with the TR 9650 Mobile Patient Combilift the system provides safe moving and handling for both patient and attendant.

During the bathing cycle the client never leaves the comfort and security of the chair or stretcher.



Specifications

Length	2080 mm / 82"
Width	780 mm / 31"
Working Load Limit	150 kg (330 lbs)
Typical lift speed, no load	8 mm/s / 0.3 inch/s
Operating height range	650 - 1000 mm / 26" - 40"
Power supply	230 V, 50 Hz, 10 A / 110 V, 60 Hz
Overall weight (empty)	appr 100 kg / 220 lbs

Dimensions (mm)

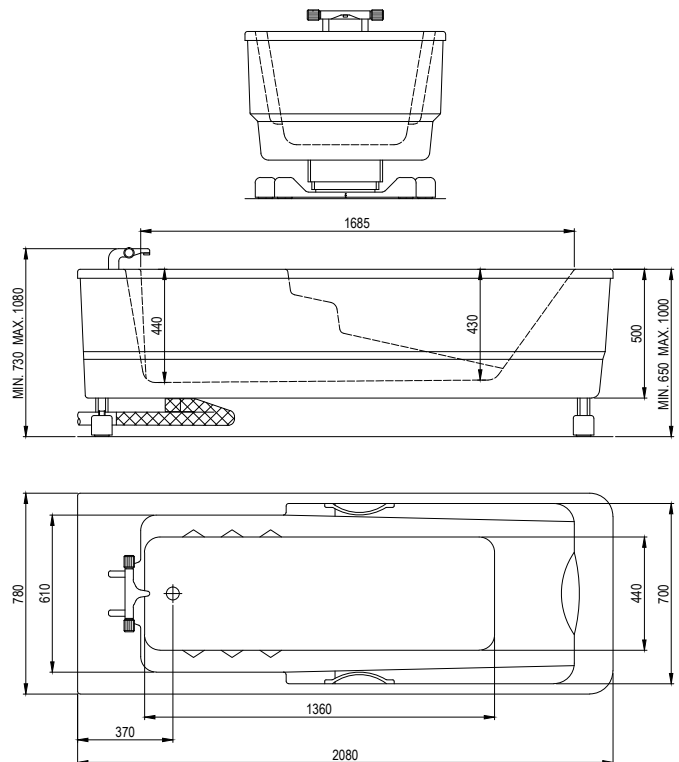

Head office

TR Equipment AB, Sweden
Phone: +46 140 38 50 60
info@trequipment.se
www.trequipment.com

Group Subsidiaries

TR Group Inc, US, Phone: +1 (800) 752 6900
TR Equipment Ltd, UK, Phone: +44 (0) 844 335 8386
TRanspoRehaMed GmbH, Germany, Phone: +49 (0) 212 645850-0



TR EQUIPMENT