

# TR Comfortline Bathtub

Hygiene Equipment  
Designed for People

## TR Comfortline, Height Adjustable Bathtub

The TR Comfortline is a free standing, height adjustable bathtub designed for a satisfying and relaxed bathing experience. With a host of sensory options available, such as LED lighting system, music sound wave system with four speakers AUX and bluetooth and a 12 jet air-spa system.



Registered at Medical Products  
Agency, Sweden,  
as a MD Class 1 product,  
MDD 93/42EEC.

TR reserves the right to make  
design changes and/or  
improvements without notice.



Used in conjunction with the TR 9650 Combilift, the Comfortline is easily accessible from either side of the bathtub. Attendants will benefit from the Comfortline's ergonomic design and efficient bathing cycle. Simple installation of the Comfortline allows it to be positioned in almost any central bathing areas or bathrooms. Controls have been designed with simplicity in mind and the smooth design makes it easy to clean and maintain.



**TR EQUIPMENT**

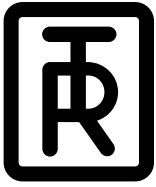

# TR Comfortline Bathtub

Hygiene Equipment  
Designed for People

## Features

- Innovative and attractive design
- Easy to operate and learn - Quick introduction
- Easy access to the bathtub from three sides
- Compact design for easy placement
- Ergonomic tub shape
- Easy to clean and maintain
- Suitable for mobile transfers (TR 9650 with Stretcher/Chair is recommended)
- Detached, no wall or floor fixing
- Reverse install configurations possible with extended hose kits

## Standard Equipment

- Hand shower with long hose
- Overflow control and pop-up drainage incl drainage hose
- High quality bathtub with side covers of reinforced fibre glass
- White as standard color
- Two chrome grab handles
- Foot support, adjustable in three positions and removable
- Reinforced hoses for water installation
- Two wide stainless steel legs with adjustable feet



## Options/Accessories available for Comfortline

- Cleaning/disinfection system
- Autofill with 2 different pre-set levels
- Bathtub and bathtub side covers in optional RAL - Color (Specify RAL code on order)
- Fixed height bath - ECOLINE
- FMM Antibactus mixer (Legionella)
- Mixer Grohe 2000, with Grohe CoolTouch system

## Wellness Options

- Air bubbles from twelve integrated jets stimulate blood circulation and provide a calming environment for relaxation.
- LED Color Light System with light that changes the water into different colors.
- Music sound wave system with four speakers AUX and bluetooth.

## Application Examples

Integrated with the TR 9650 Mobile Patient Combilift the system provides safe moving and handling for both patient and attendant.

During the bathing cycle the client never leaves the comfort and security of the chair or stretcher.



## Specifications

<b>Length</b>	2080 mm / 82"
<b>Width</b>	780 mm / 31"
<b>Working Load Limit</b>	150 kg (330 lbs)
<b>Typical lift speed, no load</b>	8 mm/s / 0.3 inch/s
<b>Operating height range</b>	650 - 1000 mm / 26" - 40"
<b>Power supply</b>	230 V, 50 Hz, 10 A / 110 V, 60 Hz
<b>Overall weight (empty)</b>	appr 100 kg / 220 lbs

## Dimensions (mm)

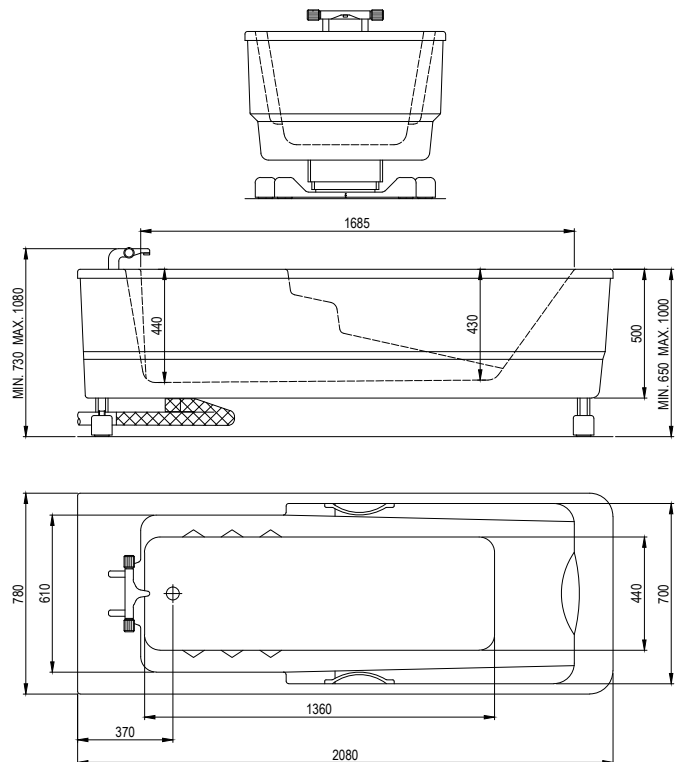

## Head office

TR Equipment AB, Sweden  
Phone: +46 140 38 50 60  
info@trequipment.se  
[www.trequipment.com](http://www.trequipment.com)

## Group Subsidiaries

TR Group Inc, US, Phone: +1 (800) 752 6900  
TR Equipment Ltd, UK, Phone: +44 (0) 844 335 8386  
TRanspoRehaMed GmbH, Germany, Phone: +49 (0) 212 645850-0



TR EQUIPMENT