



TR 1000 Shower Chair

*Hygiene Equipment
Designed for People*

TR 1000 Showering at its best

The TR 1000 Battery Operated Shower Chair is height adjustable and can be tilted backward and forward for easy and efficient transfers and showering.



CE



Registered at Medical Products Agency, Sweden, as a MD Class 1 product, MDD 93/42EEC.

TR reserves the right to make design changes and/or improvements without notice.

The TR 1000 Height Adjustable Shower Chair is a great solution to minimize static load and offers a safe and ergonomic working environment for caregivers. The full power feature of the TR 1000 allows the caregiver to use the hand control to adjust the height and tilting of the chair so that they can best position the resident to care for their individual needs. This provides a safe patient handling environment for both the resident and the caregiver.



TR EQUIPMENT



TR 1000 Shower Chair

Hygiene Equipment
Designed for People

Features

- Clean design of chassis and chair makes access easy during transfers and showering. It also makes the TR 1000 easy to clean.
- Suitable to use with most sling hoists and standing/raising aids to make transfers as smooth and safe as possible.
- Seat and chassis create possibilities for toileting over standard toilet or with a bed pan attached to the chair.
- Designed for stability and for ease in mobility and transfers.
- The rear chair design features a smooth surface for ease of cleaning.
- Belt over the hip feature for patient safety.
- The adjustable and foldable footrest ensures security and comfort for residents (available option).



Wide height adjustment range with smooth and gentle movement to give residents and caregivers a safe and comfortable showering and shampooing experience.



Recline position for the residents comfort and relaxation allowing easy access for caregiver.



The forward tilt adjustment mechanism allows easier transfers from wheelchairs and standing aids and creates security for both resident and caregiver.



Seat and backrest are designed for ease of comfort and cleanliness.



The headrest provides support and security for the residents head and neck.



Columns for height adjustment give gentle and smooth movement and provide a clean design.



Foldable armrests feature grip knobs for resident's comfort and safety.



The integrated leg rest is designed for residents comfort and ergonomic working routines.



The bed pan accessory option can be fitted to the chair to ease toileting.



Easy to understand hand control for height adjustment and tilt from any position around the chair.



Removable battery pack is easy to change making the TR 1000 simple to charge and always ready for use.



The foldable armrest accessory option features front closing for increased sense of security for residents.

Specifications



Lifting Stroke Range	400 mm (16")
Working Load Limit	200 kg (440 lbs)
Tilt Backwards (recline)	25 degrees
Tilt Forward	7 degrees
Structure	Powder coated, zinc plated steel and stainless steel
Castors	Twin Ø100 mm (4") castors with locking brakes
Control	Hand control for height adjustment and tilt
Battery	Removable and rechargeable

Models

- 0521000 Shower chair with straight armrests
- 0521010 Shower chair with front closing armrests (factory mounted)

Accessories/Options

- 0521015 Adjustable and foldable footrest
- 0521020 Chest belt
- 850169 Bed pan including lid
- 3232622 Wallbracket for battery pack

Dimensions (mm)

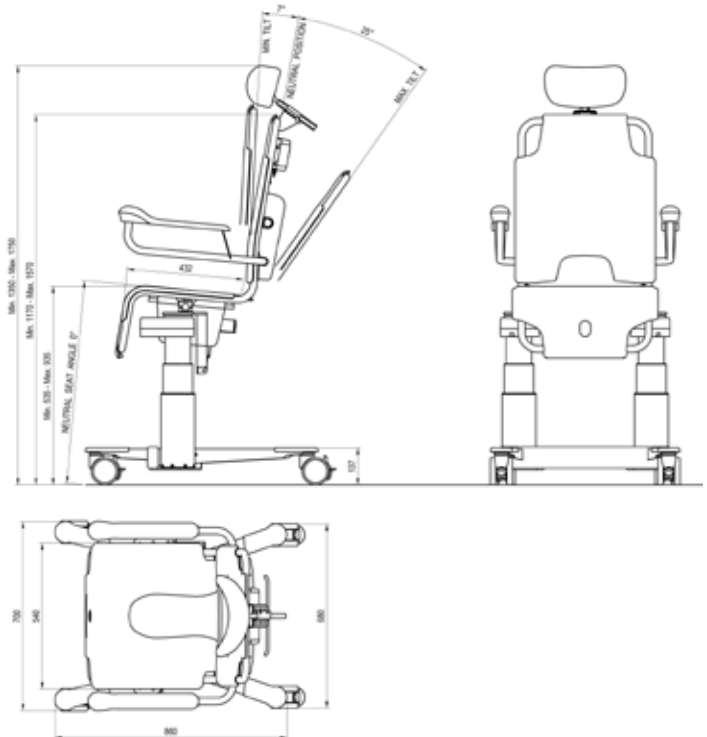

Head office

TR Equipment AB, Sweden
Phone: +46 140 38 50 60
info@trequipment.se
www.trequipment.com

TR Group Inc

130 North Madison Street
Rockford, IL61107, USA
Phone: +1 (800) 752 6900
Email: information@trequipment.com
www.trequipment.com



TR EQUIPMENT